



WhatsApp



Wechat



Twitter



Instagram

广州明睿自动化设备有限公司
Guangzhou Merry-Pack Company Limited
Building7 of CBD center, No.1006 Hulin road, Huangpu district,
Guangzhou, China
+86 20-8985 2859 | +86-180 2334 0108
Donna@merry-pack.com, mr003@merry-pack.com
www.merry-pack.com; www.merry-pack.cn;
merrypack.en.made-in-china.com

GMP 日化&制药设备制造商
GMP Daily Chemical & Pharmaceutical
Equipment Manufacturer

广州明睿自动化设备有限公司
Guangzhou Merry-Pack Co.,LTD



A 关于我们 About us

Our dedication to superior integrated filling packaging solutions allows our customers to reach their production, financial, strategic and marketing goals. At Merry-Pack company creativity and innovation are strategic factors to which the company is firmly committed through the continuous reinforcement of R&D and Engineering departments in the search for new knowledge that anticipates market needs. Merry-Pack's main objective has always been providing additional value to their customers.



QUALIFICATION HONOR

资质荣誉



工艺流程图

PROCESS FLOW DIAGRAM



Cream/Paste/Lotion Production line 膏霜生产线

RO System - Vacuum Emulsifying Mixer - Storage Tank - Bottle Cleaning/Sterilizing Machine - Filling Machine - Capping Machine - Alu Foil Sealing Machine - Labeling Machine - Inkjet Printer - Shrink Film Packing Machine



Liquid Washing Production line 液洗生产线

RO System - Pure Water Tank - Homogenizer Mixer - Storage Tank - Turntable - Filling Machine - Capping Machine - Labeling Machine - Inkjet Printer - Finished product collect table - Shrink Film Packing Machine



Perfume Production line 香水生产线

RO System - Pure Water Tank - Perfume Freezing Mixer - Storage Tank - Filling Machine - Crimping Machine - Collaring Machine - Labeling Machine - Inkjet Printer - Box Wrapping Packing Machine

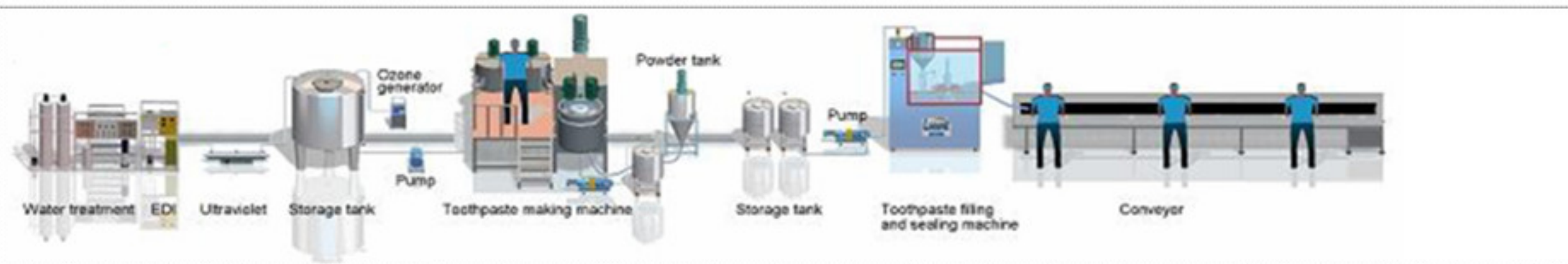

Toothpaste Production line 牙膏生产线

RO System - Pure Water Tank - Vacuum Toothpaste Mixer - Storage Tank - Tube Filling Sealing Machine - Cartoning Machine - Inkjet Printer - Conveyor Workbench

真空均质乳化机

VACUUM EMULSIFYING MIXER



What is vacuum emulsifier?

It means that when the materials are under the vacuum condition, it makes use of the high shear emulsifier to distribute one or several phases to another continuous phase rapidly and evenly. The materials will be processed in the narrow space between stator and rotor by strong energy of motion produced by the mechanical effect. By the operation of hydraulic shearing, centrifugal extruding, impacting, breaking and turbulence for over 100 thousand times per minute, the materials will be dispersed and emulsified instantly and evenly. After reciprocating circulation at high frequency, the fine finished products of stable and high quality without bubbles will be achieved.

真空乳化机工艺流程图

FLOW CHART OF VACUUM EMULSIFYING MIXER

真空乳化机工艺流程 Flow chart of vacuum emulsifying mixer

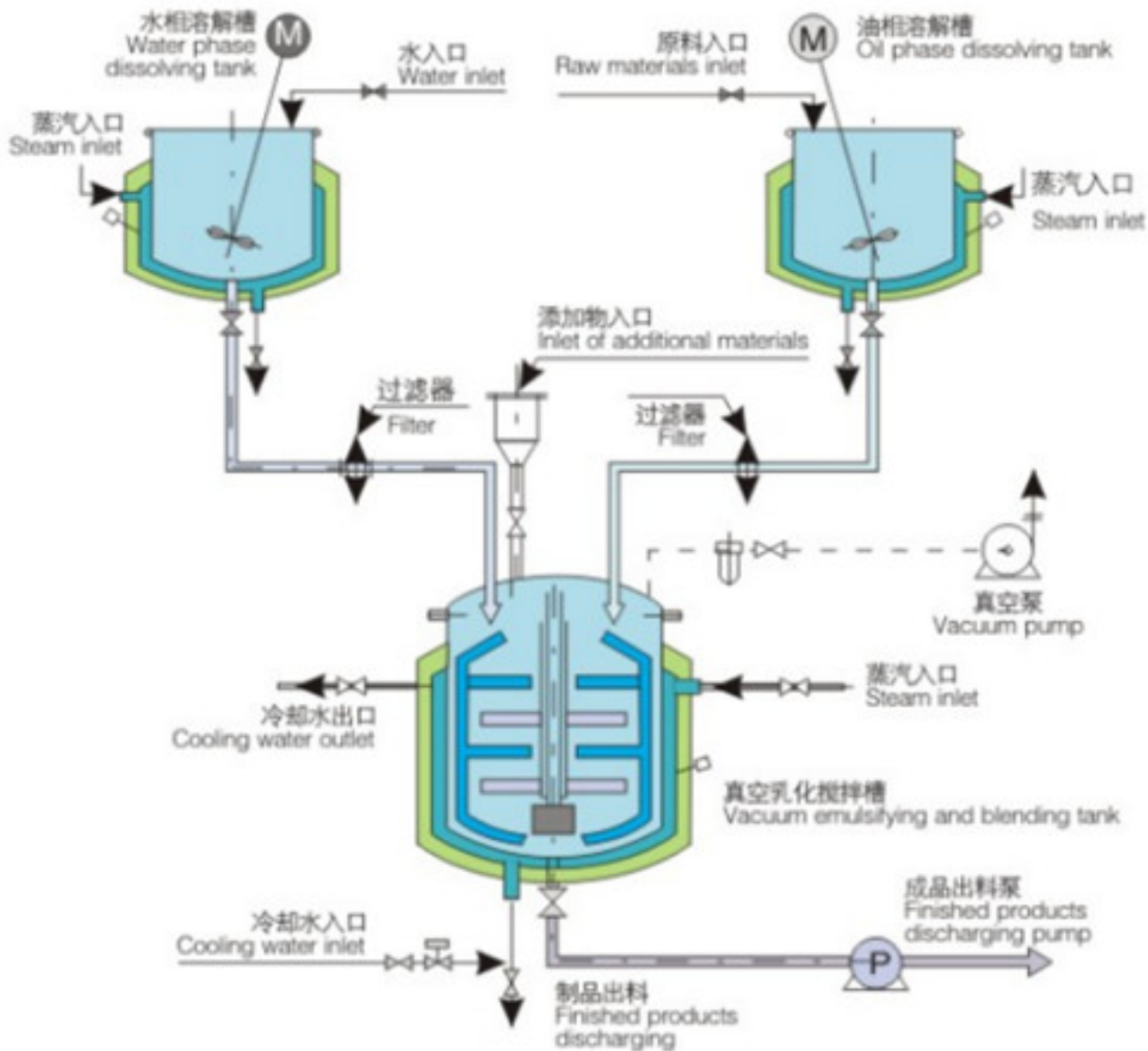

The vacuum emulsifying mixer is mainly composed of water/oil pot, emulsifying pot, vacuum system, lifting system (optional), electric control system (PLC is optional), operation platform, etc.

真空乳化机主要是指物料在真空的状态下,利用高剪切乳化器快速均匀地将一个相或多个相分布至另一个连续相中,利用机械带来的强劲动能,使物料在定子狭窄的间隙中,每分钟承受几十万次的液力剪切。离心挤压撞击撕裂等综合作用,瞬间均匀地分散乳化,经过高频的循环往复,最终得到无气泡又极细腻的高品质乳化产品

Model	Capacity	Water pot	Oil Pot	Lifting	Homogenizer	Agitator	Vacuum	Heating
RHJ-20	20L	14L	8L	0.75kw	1.5kw	0.55kw	0.55kw	3Kw
RHJ-50	50L	35L	20L	0.75kw	2.2kw	0.75kw	0.75kw	9Kw
RHJ-100	100L	70L	40L	1.5kw	3kw	1.5kw	1.55kw	12Kw
RHJ-200	200L	140L	80L	1.5kw	4kw	2.2kw	2.35kw	18Kw
RHJ-300	300L	210L	120L	1.5kw	5.5kw	3kw	2.35kw	24Kw
RHJ-500	500L	350L	200L	1.75kw	7.5kw	4kw	3.85kw	36Kw

ONE-STOP SERVICE

满足GMP标准的
化妆品机械设备供应商

Supplier of cosmetic machinery
and equipment meeting the GMP standard

PLC控制系列真空均质乳化机

RHJ-A PLC CONTROL SERIES VACUUM EMULSIFYING MIXER



PLC Control With Pneumatic Valve



PLC Control With Upper Homogenizer

PLC控制固定式真空乳化机

RHJ-A PLC CONTROL SERIES VACUUM EMULSIFYING MIXER

More functions: Support the manual operation and PLC HMI operation, the highest vacuum degree can be reached to -0.095MPa .

More supporting: Can be selected the CIP/SIP system and error prevention system, which can completely make sure the security of the products:

More options: The homogeneity can be divided into upper and under homogeneity and external circulation structure, the stir can be



PLC Control With Steam Heating

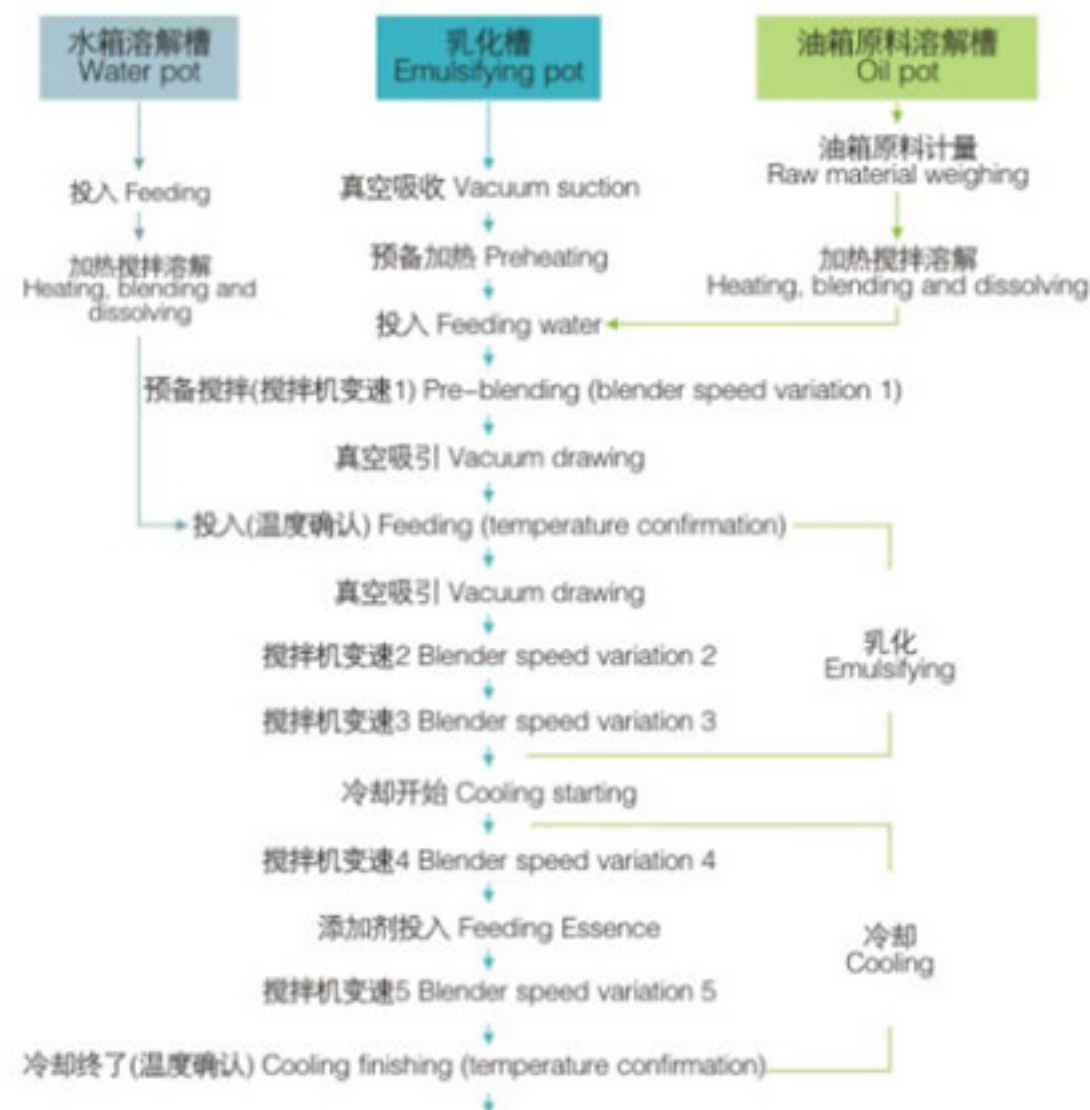

上均质真空均质乳化机

RHJ-B UPPER HOMOGENIZER VACUUM EMULSIFYING MIXER



This series upper homogenizer emulsifying machine adopts two mixing speed on one shaft to make product more smooth, homogenizer makes it upper in the perfect position to reach best emulsion function, homogenizer speed can make up to 0-3600RPM, hydraulic lifting system for product outlet and machine clean and maintenance more convenience.

上均质真空均质乳化机

UPPER HOMOGENIZER VACUUM EMULSIFYING MIXER



下均质真空均质乳化机

RHJ-C BOTTOM HOMOGENIZER VACUUM EMULSIFYING MIXER



RHJ-C-50L



RHJ-C-20L

下均质真空均质乳化机

RHJ-C BOTTOM HOMOGENIZER VACUUM EMULSIFYING MIXER



RHJ-C-500L



RHJ-C-200L

Vacuum homogenizing emulsifier is a complete set of emulsifying mixing, dispersing, homogenizing, and aspirating multi-functional system with the electronic control system and can also be used with oil/water pot, vacuum system, hydraulic lifting, heating/cooling, etc. Is the production of medicinal ointment, high-grade cream, lotion and other special equipment.



RHJ-C-10L

固定式真空均质乳化机

RHJ-D MANHOLE SEALING VACUUM EMULSIFYING MIXER



RHJ-D-500L Manhole Sealing Homogenizer

固定式真空均质乳化机

RHJ-D MANHOLE SEALING VACUUM EMULSIFYING MIXER



RHJ-D-500L Int & ext Circulation homogenizer



RHJ-D-500L Single Tank Mixer



RHJ-D-1000L Combination Tank Mixer

非标真空均质乳化机

RHJ-E CUSTOMIZED VACUUM EMULSIFYING MIXER



非标真空均质乳化机

RHJ-E CUSTOMIZED VACUUM EMULSIFYING MIXER

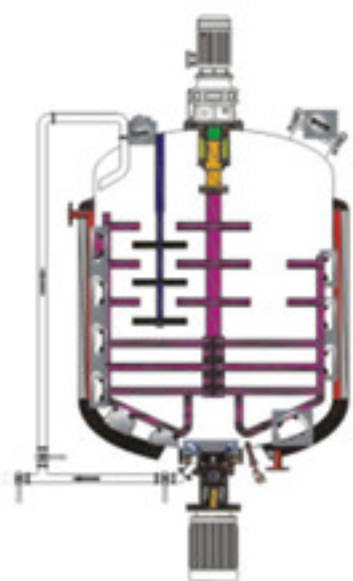

Single way mixing
internal external

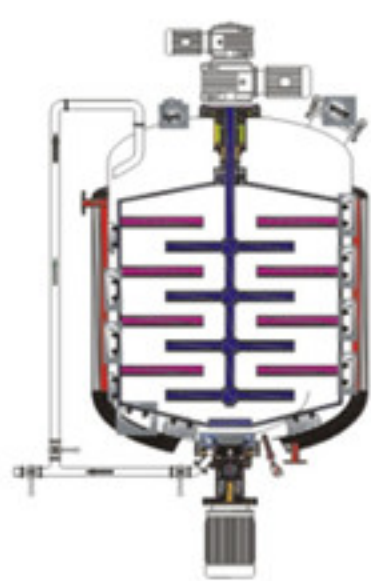

Double way mixing
internal external

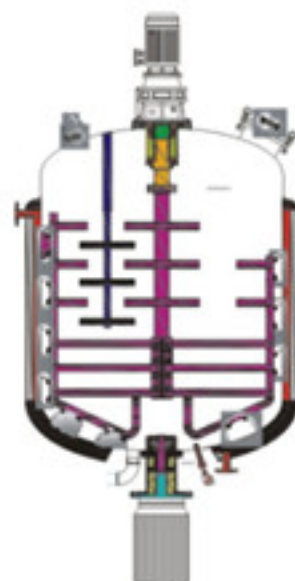

Single way mixing
internal circulation

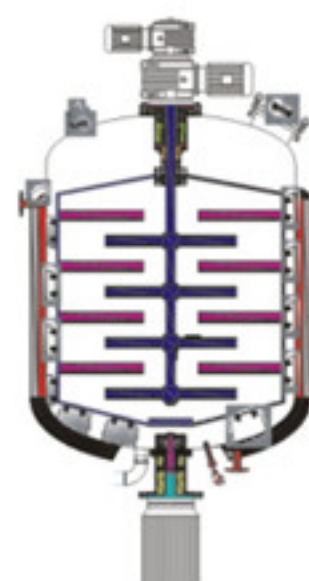

Double way mixing
internal circulation

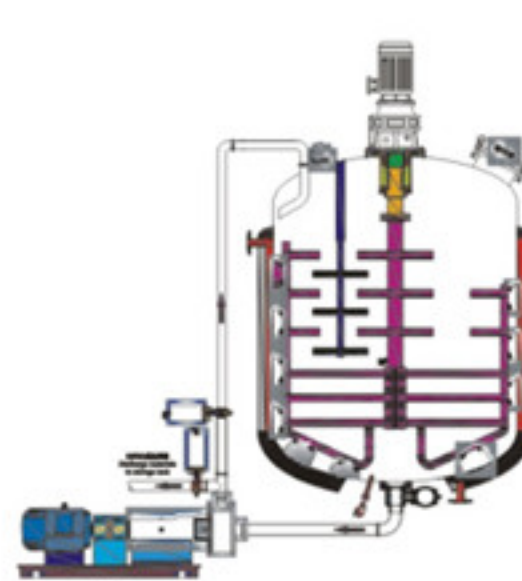

Single way mixing
external homogenizer

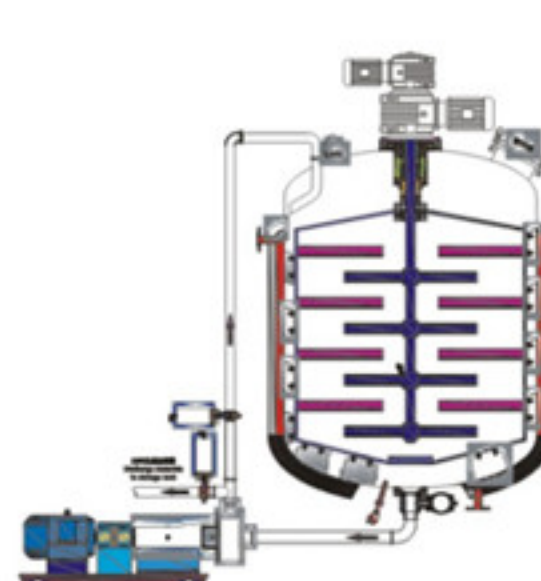

Double way mixing
external homogenizer

真空牙膏机

RHJ-T VACUUM TOOTHPASTE MAKING MACHINE

RHJ-T

Vacuum Paste & Cream Making Machine
真空制膏机

TOOTHPASTE



真空牙膏机

RHJ-T VACUUM TOOTHPASTE MAKING MACHINE



真空制膏机系列广泛用于牙膏、化妆品、食品、化工等行业粘稠膏体的制造。全套设备配有制膏机、预混锅、胶水锅、粉料斗、胶体泵、操作平台。

The vacuum machine produced by our company is widely used for manufacturing paste-like products, toothpaste, cosmetics, foods and chemistry industry, etc. This equipment includes paste machine, pre-mix boiler, glue water boiler, powder material hopper, colloid pump and operation platform.

主要技术参数 Technical parameter

型号 Type	工作容量 Volume(L)	真空泵 Power of Vacuum Pump (kw)	液压泵 Hydraulic Pump (kw)	锅盖升降高度 Lifting Height of Vessel Cover(mm)	外形尺寸 Dimension (L x W x H) (mm)	整机重量 Weight (kg)
RHJ-T-100	100	3	1.1	800	2450 x 1500 x 2040	2500
RHJ-T-500	500	4	1.5	1000	4530 x 3800 x 2480	3000
RHJ-T-1000	1000	5.5	2.2	1000	1920 x 2910 x 3200	4500

液洗均质搅拌锅

JBJ LIQUID WASHING HOMOGENIZER MIXER



The all-round wall scraping mixing adopts the frequency converter for speed adjustment. The diversified high-speed homogenizer can powerfully mix solid and liquid raw materials and can rapidly dissolve many indissoluble materials such as AES, AESA, LSA, etc. during the liquid detergent production process so as to save energy consumption and shorten production period.

液洗均质搅拌锅

JBJ LIQUID WASHING HOMOGENIZER MIXER

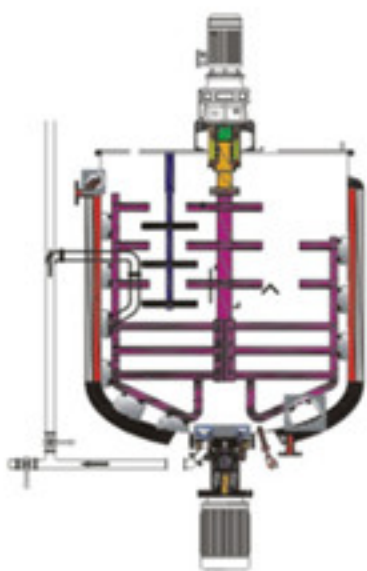

Single way mixing
internal external

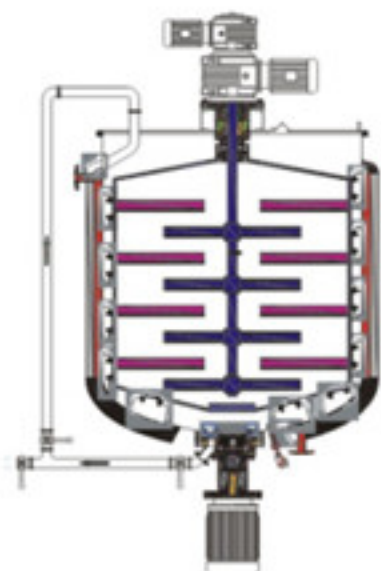

Double way mixing
internal external

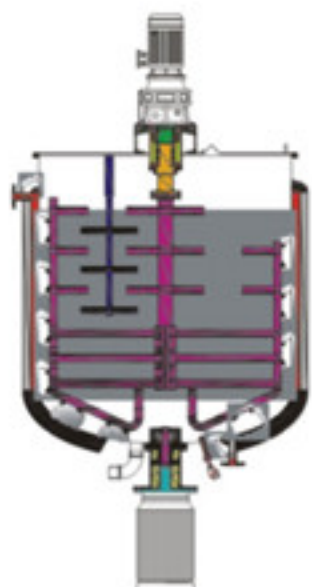

Single way mixing
internal circulation

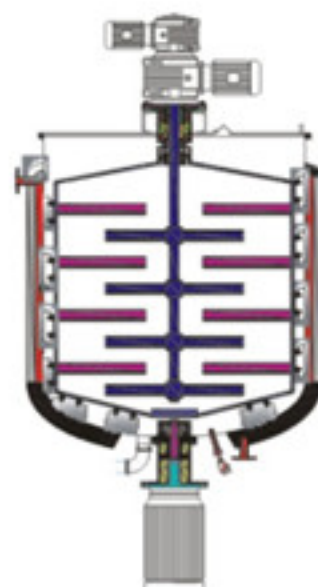

Double way mixing
internal circulation

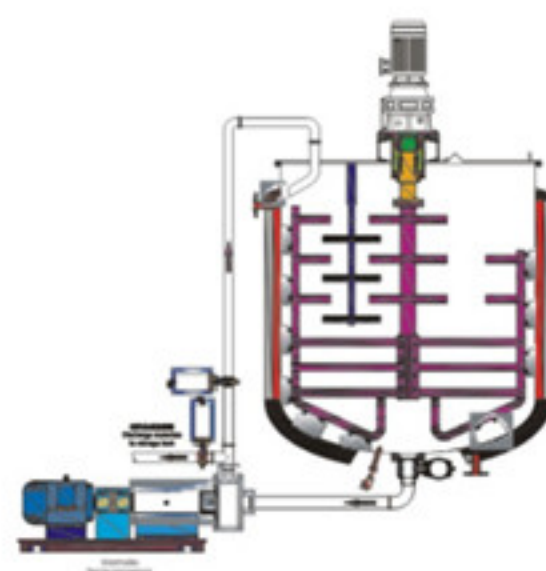

Single way mixing
external homogenizer

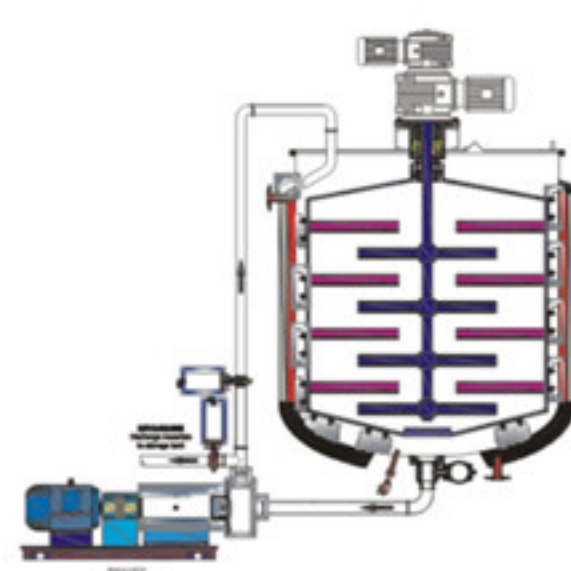

Double way mixing
external homogenizer

聚丙烯防腐搅拌锅

JBJ-G PP ANTI-CORROSIVE MIXER



This PP/PVC plastic mixer is mainly used in chemical, medicine, petroleum, and other industrial lines. It is specially for the strong causticity product. Such as the strong acid and alkali and the water for hair care product.

The mixer pot is made of PP/PVC/plastic material. It is very hard to reaction with any chemical product. The stirring blade is made of enamel. This machine has explosion preventin motor. It is very easy to operate, light, also can naticorrosive.

The work pressures $< -0.01\text{Mpa}$,
work temperature (PP): $-10^{\circ}\text{C}\sim 100^{\circ}\text{C}$
PVC $-10^{\circ}\text{C}\sim 60^{\circ}\text{C}$.

V型和螺带搅拌机

JBJ-V & JBJ-U V TYPE AND RIBBON MIXER



V Type Mixer



Horizontal Ribbon Rixer

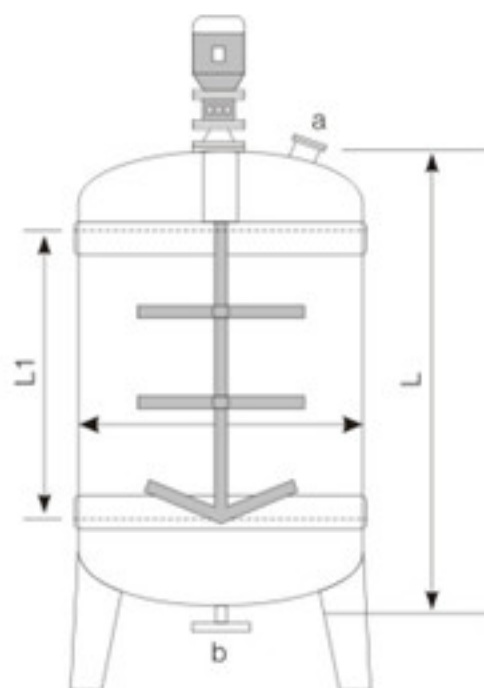

Model	Capacity	φ	L	L1	a	b	Power	Speed
G800	800L	800	1340	800	380	50	2.2kw	0-63RPM
G1000	1000L	1000	1550	1000	400	50	3kw	0-63RPM
G2000	2000L	1650	2000	1500	450	50	3kw	0-63RPM

气动升降均质机/吊式均质机

JBJ PNEUMATIC LIFTING HOMOGENIZER



气动升降分散机/均质头

JBJ DISPERSER AND HOMOGENIZER



Pneumatic lifting
disperser



Homogenizer A



Homogenizer B



Homogenizer C

儲罐系列

CG STORAGE TANK SERIES



Flip-open Cover Storage Tank



Manhole Open Storage Tank



Horizontal Storage Tank



Constant Temperature Tank

儲罐系列

CG STORAGE TANK SERIES



Flip-open Cover Mixing Tank



Manhole Sealing type Mixing Tanks



Storage Tank With Liquidometer

RO 反渗透纯水系统

RO REVERSE OSMOSIS WATER TREATMENT



MRO-1000L/H RO Water Treatment (PVC)



MRO-500L/H Two Stage RO Water Treatment

RO 反渗透纯水系统

RO REVERSE OSMOSIS WATER TREATMENT



MRO-1000L/H RO Water Treatment (SUS)



MRO-500L/H Two Stage RO Water Treatment + EDI



EDI System



Ozone Generator

UV Sterilizer



Raw water tank

Water pump

Sand filter

Carbon filter

Softener

Water tank

PP Filter

Two stage RO system

Pure water tank

EDI System

EDI water tank

Two stage RO water tank

Pure water pump

UV Sterilizer

香水机系列

PERFUME MACHINE SERIES



PF-A Perfume freezing machine



PF-A Perfume freezing machine



PF-B Perfume freezing machine



Four Nozzles Perfume filler



Two Nozzles Perfume filler

香水机系列

PERFUME MACHINE SERIES

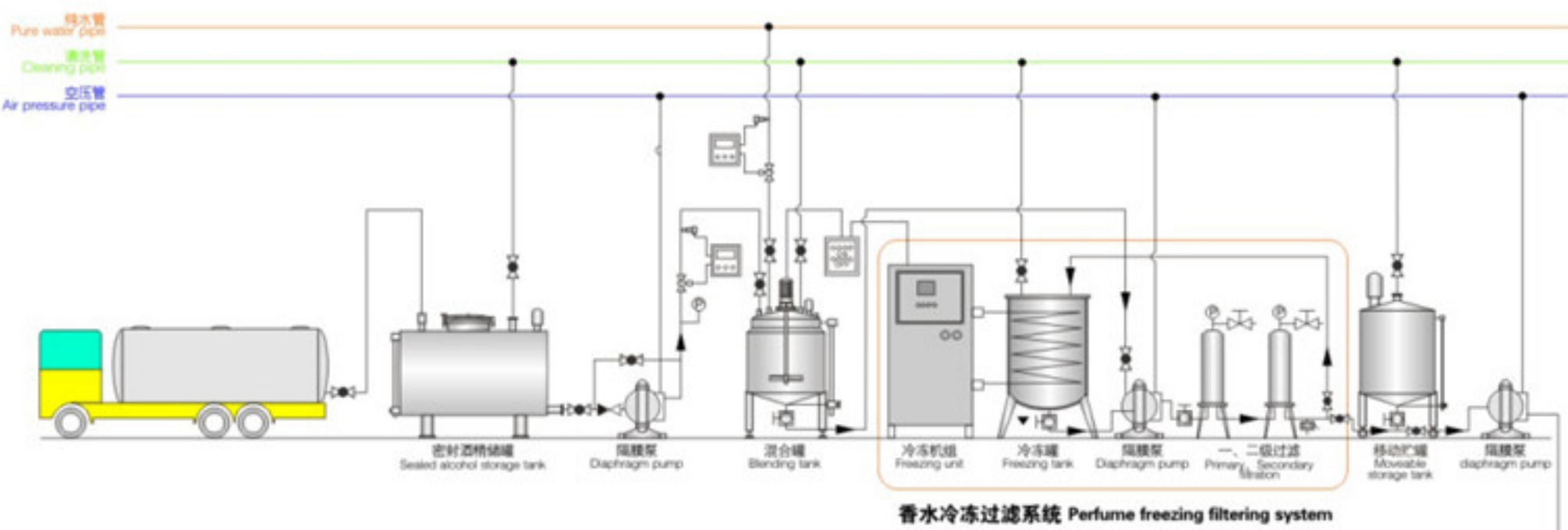

Bottle neck crimping machine



Manual crimping machine



Plate frame type filter

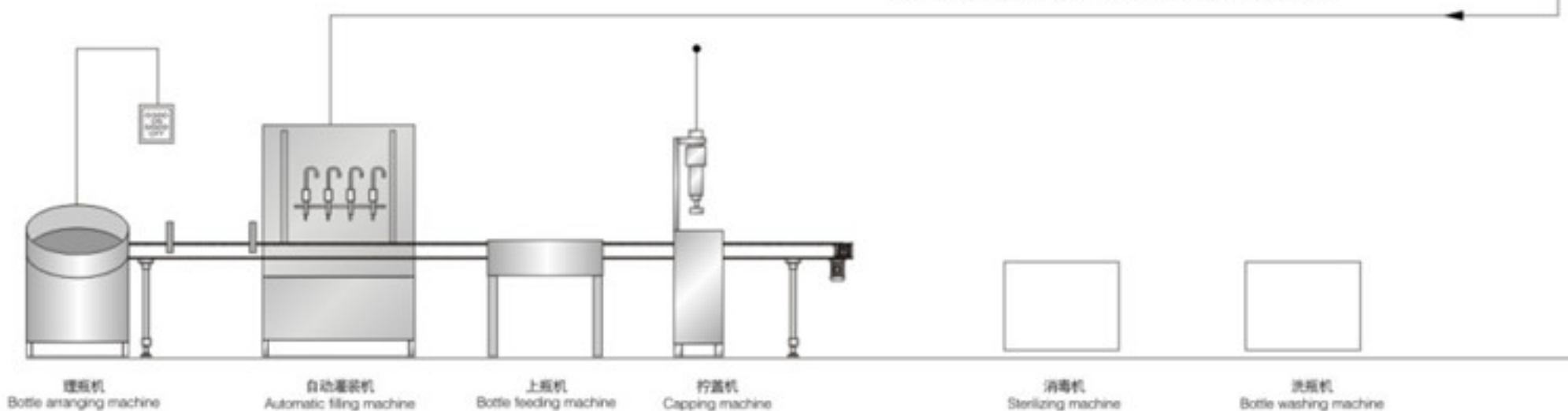

Microporous film filter



Filter shell



Filter element

理瓶机

自动灌装

上瓶机

打盖机

消毒机

洗瓶机

彩妆设备系列

MAKEUP COSMETIC MACHINE



Three Axis Powder
Mixing Machine



Shaking Sieve
Powder Machine



Auto Powder
Pressing Machine



Manual Powder
Pressing Machine

彩妆设备系列

MAKEUP COSMETIC MACHINE



Three Roller Milling
Machine



Lipstick Mixer



Twelve Nozzles
Lipstick Filler



Lipstick Freezing
Tunnel machine



Lipstick mould
removing machine



Compact powder production

Powder mixer--- Aspiration grinder for powder---shaking sieve powder machine--- Compact powder pressing machine (Optional: conveyor)



Lipstick Production line

RO Pure water treatment---Lipstick mixer---Three-roll grinder---Storage tanks---Lipstick Filling machine---Tunnel-based refrigerator (Chiller)---Air-blowing Machine for lipstick (Optional: conveyor)

输送泵类和蒸汽锅炉

TRANSFER PUMP AND STEAM GENERATOR



Rotor Pump



Emulsion Pump



Screw Pump



Diaphragm Pump



Gearing Pump



Steam Generator



不锈钢配件

STAINLESS STEEL ACCESSORIES

